

Mi Water Purifier 400G (model for kitchen)

Content

Before using the device read the instructions carefully

Installation

1. This device must be installed by authorized specialists of network service of Xiaomi company.
2. If you receive Mi Water Purifier and you need to make the installation of the device, you should:
 - (1) Call the hotline 400-100 5678 and order the installation of the device;
 - (2) Do go to website of online service <http://www.mi.com/service> and order the installation of the device.

User`s manual

Regulation of water supply

After installing the device, turn Mi Water Purifier on for supplying purified water and close the valve to stop the flow of pure water.

Note: If water temperature and pressure, relatively low supply pressure of clean water will be weak.

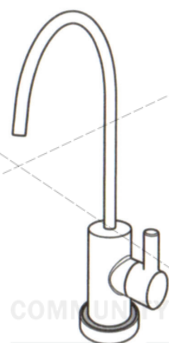

Sphere of usage

The device is suitable only for filtering water, that meets GB 5749 «drinking water» standard. Filtered water is suitable for everyday drinking.

User`s manual.....	1
Device and accessories.....	2
Chematic map.....	3
Connecting to..... WiFi.....	4
Installation of filter cartridges.....	4
Lifetime of filter cartridges and purchasing new.....	5
Changing of filter cartridges.....	5
List of faults and repair.....	6
Cautions.....	7
Main specifications.....	8
The presence of toxic and hazardous substances.....	8
Water processing technology.....	9
The electrical circuit.....	9
Warranty.....	10

Equipment



The main box

Includes pipeline to supply water, piping to remove water, concentrated water conduit and cable tap for purified water.

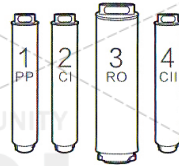

4 filter cartridges

Cut the package and remove all 4 filters, install the main unit, according to their serial number.

Accessories

Stainless steel tap and three-way ball valve



Manual and Warranty card

Accessories

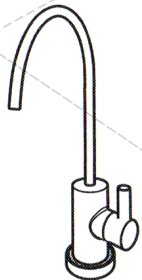

Stainless steel tap x1

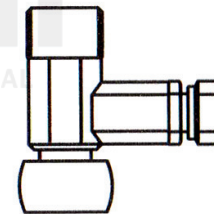

Three-way ball valve x1

Schematic map

Faucet

Tap for purified water

Indicators of tap for purified water

Permanent blue LED indicator: normal use;
Permanent yellow LED indicator: problems with water quality;
Flashing yellow LED indicator: automatic water run.

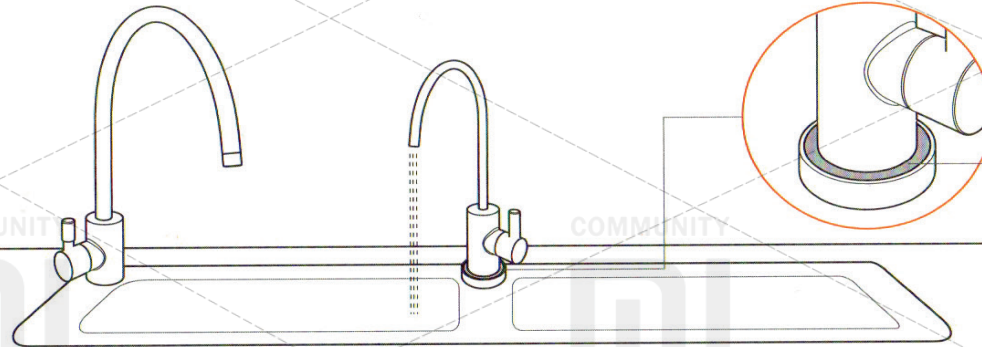

Protective cover

4 filters

Cable of tap for water
Pipeline for water

purified
purified

Pipeline for concentrated (not drinking water, to sewer)

utilization impurities connected

Pipeline for water

Faucet

Three-way ball valve

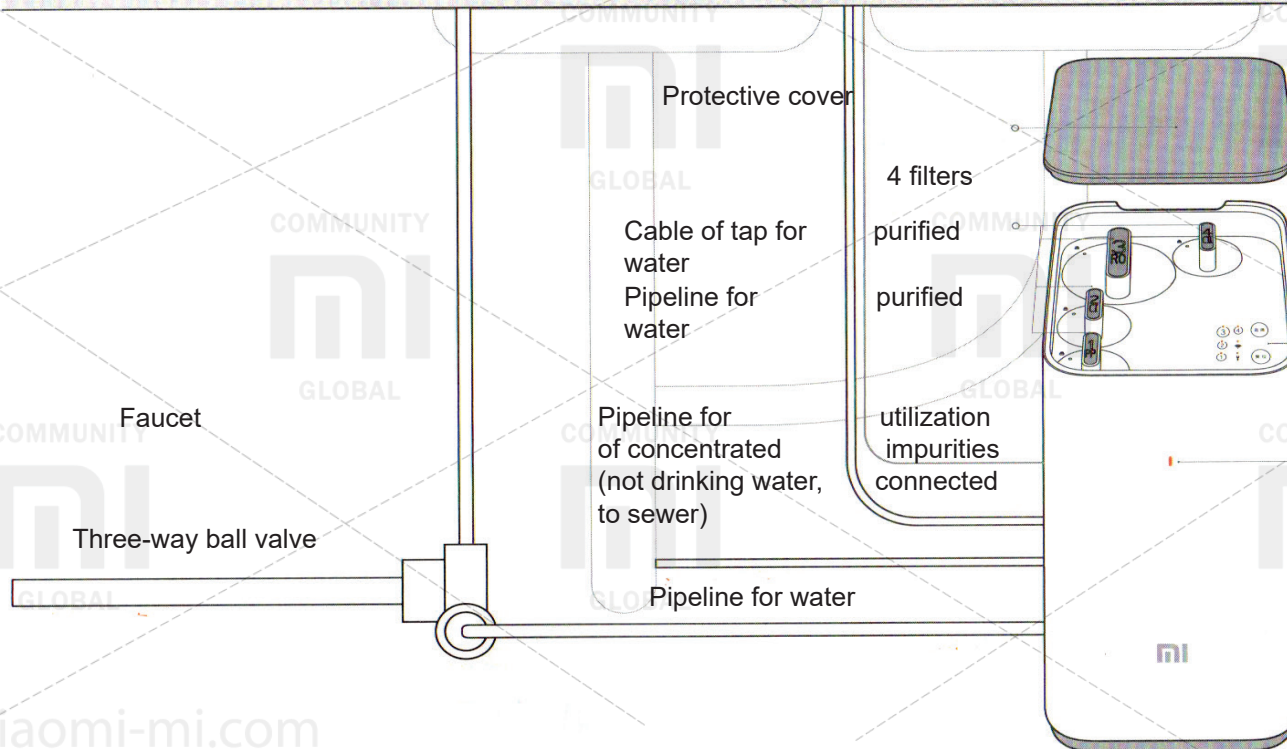

Reset of Wi-Fi
Click and hold for 3 seconds

The control panel of the main unit

- ① 1. LED Indicator of PP cotton filter lifetime
- ② 2. Lifetime indicator of input filter with activated carbon
- ③ 3. Lifetime indicator of reverse osmosis filter
- ④ 4. Lifetime indicator of last filter cartridge with activated carbon
- Wi-Fi Wi-Fi indicator
- Indicator of faults
- 选择 Select button of filter cartridge
- 复位 Reset button of filter cartridge

Status indicators

Blue light: normal use
Orange light: the emergence of faults

Step by step installation

1 Installing filter cartridges

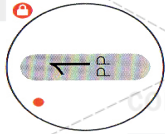

01 Remove filter cartridges from packaging

02 Insert first filter cartridge to corresponding well in such a manner that the lever of cartridge pointing to 9:00 (Figure 2).

Slightly press down filter cartridge and rotate it counter-clockwise by 90%.

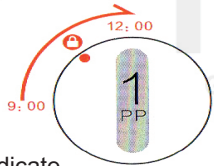

03

A A round point, directed at the lock icon (Figure 2).

B Cartridge's handle points to 12:00 pm (Figure 2)

C Surface of filter cartridge is at the same level with surface of the base unit (Figure 3).

3 points that indicate correct position of the filter cartridge:

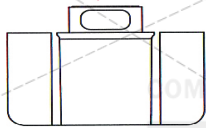

04 In turn, install remaining cartridges 2,3,4 in the same way (Figure 4).

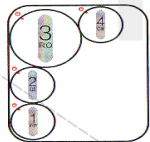

05 After installation, you must necessarily within 10 minutes run water through purifier.

Note: You need to get rid of water, to rinse filter cartridges and tubes. You may see a grayish water or water with bubbles, it is normal to drain water until it is clear. When you first use it is necessary to wait a relatively long time, but please be patient.

2 Connecting to WiFi

Connecting to power

Plug a power cable into the socket of water purifier.
More Smart devices you find on our site mi.com or purchase devices via mobile app Mi «Smart Home».



Downloading the app

In APP Store find and download mobile application «My Water Purifier» or scan the QR-Code.

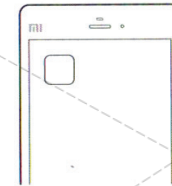

Connecting to Wi-Fi

When you connect a smartphone to open Wi-Fi, start the application and follow onscreen instructions.

Reset of Wi-Fi

Simultaneous pressing for 3 seconds.



Changing filter cartridge

Expiration of filter cartridge operation

Value of indicators:

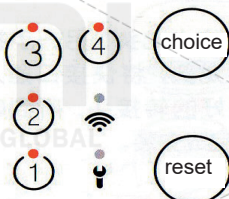

appearance of a flashing orange indicator on any filter cartridge indicates that it will soon come to an end of its life.
 appearance of steady orange light over any filter cartridge means that it is reaching to an end of its lifetime.
 Warning: can simultaneously light indicators of overall filter status.

Buy filter cartridge:

01. Register to www.xiaomi-mi.com;
02. Application «Smart Home»;
03. Scan QR-code.

Recommended terms to replace filter cartridges:

Level	Cartridge name	Main function	Objects that are filtered	Time of replacing the filter
1 Level	Filter cartridge with PP cotton	Primary treatment, filters relatively large foreign objects	precipitate fiber, rust and other visible foreign matter	3~6 months
2 Level	input filter cartridge with activated carbon	adsorption of bad odors, color, residues of chlorine and some organic substances	Smells, unconventional color of water, remains of chlorine, trichloromethane, carbon tetrachloride and other organic substances	6~12 months
3 Level	RO reverse osmosis filter	filtering accuracy of 0.0001 microns, effectively filters out heavy metals, bacteria, organic substances, etc.	Heavy metals, bacteria, viruses, scale, organic Agents, etc.	18~24 months
4 Level	last filter cartridge with activated carbon	adsorption of bad odors, improve taste	bad smell	6~12 months

Replace filter cartridge with a new and reset

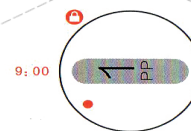

01 Before you withdraw old filter, do not turn on water for 2 minutes.

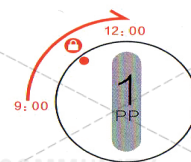

02 According to description of steps 1,2,3 «step by step installation of 1» - «Installing filter cartridge 4», replace old filter with a new (Figure 1,2,3).

03 After switching on, press «Select» and select a new filter cartridge on which indicator lights. Press and hold «Reset» button for 3 seconds after you hear the buzzer, the light goes off. Reset completed successfully (Figure 4).

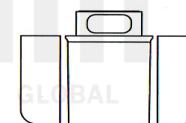

04 After installing filter, be sure within 10 minutes to run water through on water purifier.

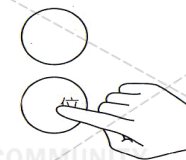

Note: You need to get rid of water, to rinse filter cartridges and tubes. You may see a grayish water or water with bubbles, it is normal to drain water until it is clear.

Note: you must do a factory reset of a new filter cartridge, or an incorrect count will discontinue its life.

Troubleshooting

List of faults

Indicator	status	Cause	Way to fix
	Flashing orange LED	Water Pump overheating protection	You can verify this problem through mobile app
	A steady orange light	Incorrect device operation	
	Rapid blinking orange LED	prolonged absence of Wi-Fi connection or its total absence	Strengthening Wi-Fi signal or reset Wi-Fi connection
	Fast blinking Blue LED	Interrupting Wi-Fi connection	
	Flashing orange light	Expiring soon operation lifetime of filter cartridge	Purchase of a new filter cartridge and its timely replacement
	Constant orange light	end of lifetime of filter cartridge	
indicator on the front side of filter	Fast blinking orange light	prolonged absence of Wi-Fi connection or its total absence	Strengthening Wi-Fi signal or reset the Wi-Fi connection
	Slowly blinking orange light	Expiring soon operation lifetime of filter cartridge or water pump overheating protection	
	A steady orange light	Expiring soon operation lifetime of filter cartridge or malfunction	
	A steady orange light	Problems with water quality or filter has not been used for a long time	Run through purified water until orange LED does not change color to blue
		Expiration of lifetime of filter cartridge	Purchase of a new filter cartridge and its timely replacement
	Flashing orange LED	Excessing water temperature	Permissible temperature of ordinary water up to 38 C. and not higher

Malfunction	Checklist
Problems with management of clean water supply	power cable connected filter cartridges are installed correctly Flashing indicators, which are displaying faults Normal water supply valve is unscrewed You are using truly reliable filter cartridge
Problems with the withdrawal of the concentrated impurity	Check pipe for the presence of bends and make sure it is a good bandwidth (check for clogged pipe)
Low clean water pressure	Check all filter cartridges, make sure they are not blocked and it is not time to replace them Make sure of correct temperature range of not filtered water and check water pressure (it should not be very weak), you can increase temperature of water not filtered, but it should not exceed 38 C. Check adapter, if it is dirty or clogged, you need to rinse it
High levels of TDS	in case if water purifier is not used for a long time It is time to replace filter cartridge
Clean water supply is switched to the normal flow of unfiltered water	make sure that temperature of filtered water does not exceed 38 C. As a result of long-term use of device turned on function of protection against overheating, wait for a while until it cools down, and then continue to use it Check possible causes in mobile application Ensure proper installation of filter cartridges

Safety measures

Antifreeze:

Do not store device in rooms with temperatures below 0C and not to succumb to its effects of low temperatures.

Water pressure:

This device is used to purify tap water or use it for other assignments
To guarantee quality of water, use this unit for tap water pressure 0,1-0,4MPa, in case of excess pressure on inlet point, use a pressure reducing valve.

Prevention:

In case of failure, quickly stop water supply, turn off power and call service: 400 100 5678
Do not disassemble device, please use a specialized repair

When moving or transporting this product, you must pack it according to directions on box, to prevent damage to filter.

Regularly clean adapter from the rain, sawdust and other debris as plugging adapter affects flow rate of clean water. Clearing adapter should be returned to its original place steel mesh and O-ring.

While wiping filter, do not let water filter cartridge to get inside the device, because soon there will be an unpleasant smell, bacteria can form water stagnation, which eventually will flow through filter microcracks.

Do not use water to wash inside or outside of

filter, because stagnant water can be formed, and hence unpleasant odor and bacteria.

flashing orange light over a particular filter cartridge will notify you that cartridge must be replaced soon. Buy and timely change filter cartridge.

Use:

For more convenient use of water purifier, use connection of Wi-Fi.

If for a long time you do not use a water purifier, turn off power and close valve of mixer. During use of filter, will appear orange light. Continue to use water for as long as indicator again turns blue indicating the normal state.

In case of turning off normal water or during repair of pipes, turn off power and close valve of faucet. Upon renewal of water supply, open other valves to allow sediment to flow down and only then device can be used again. Otherwise, a large amount of sediment after turning off of water or after a pipe repair will immediately fall into filter cartridges and quickly clog them.

If quality of filtered water is very bad, temperature and water pressure is very low, flow of purified water will be relatively weak, this is normal.

The reason for small noise and vibration when using pure water is booster pump's work, this is normal.
Do not put a filter on its side or upside down.

Do not use water purifier at a temperature below 5 ° C or above 38 C., as it may cause damage to unit.

Do not use it in public locations.

Additional accessories and filter cartridges:

For proper operation and safety of device, use additional components and filter cartridges that are only of same brand.

Storage:

Do not use it in public locations. Device storing: Constant sunlight to filter facilitates rapid «aging» of its components.

Damage to devices or filter cartridges, in the result of use of water at a temperature below 5C or above 38 C.

Close location of device near to high temperatures or powerful magnetic devices can contribute to a fire or damage to electrical circuit.

Placing device in humid or very gathering dust areas can contribute to emergence of a circuit failure.
Do not place heavy objects on filter or liquid containers.

Children with mental disabilities:

After removing device from package, avoid any child contact with box.

Do not allow children to contact, pull, play with device.

Using by children with intellectual disabilities only under the supervision of a guardian.

Safety measures

Other important factors are:

Install unit in a safe place from insects or other pests, they can chew through power cord.

Before using, firmly install plumbing. If you notice water leakage in device, immediately turn off power and water supply.

Do not install or use unit near a source of heat or fire.

Do not install or use device close to flammable, explosive devices and high-power magnetic devices.

Do not put purifier in water to wash it.

Mi is using RO water purifier RO reverse osmosis technology. In course of its work generates concentrated water, ratio is about 50% ± 10%. The quality of water pressure, water temperature, time of use purifier and its usage habits affect the production of concentrated water.

* Test conditions: tap water, the water pressure 0.2MPa, the water temperature is 25° C, after 2 minutes of continuous operation, we tested.

Main specifications

Name	Mi Water Purifier RO reverse osmosis	Nominal pure water volume	1200l	Nominal voltage	220 V
Model	MR424	Water flow rate	1.0 l/min	Rated frequency	50 Hz
Sizes	260x205x410mm	Water Pressure	0.1-0.4 mPa	Rated power	96 W
Weight	11.3kg	Temperature mode of tap water	5-38°C	standard	Q / YM001-2015 Water Purifier RO reverse osmosis for domestic use or for similar applications
Conduit of concentrated impurity	1.2m	model with protection against electric shock	2 type	license number of the health ministry	Guangdong, 2015, license number S2116
The length of power cord	1.5m	W-Fi connection	This device is certified by model number: CMIIT ID: Module 2014DR5056		
Water quality	Water quality requirements and standards of sanitary safety devices that handle domestic and drinking water (2001).				

* MR24 for Mi Water Purifier (400G)

* Water consumption according to above testing conditions

Наличие токсичных и вредных веществ

	Pb	Hg	Cd	Cr ⁶⁺	PBB	PBDE
Outer casing	0	0	0	0	0	0
Resistors	0	0	0	0	0	0
Filter cartridges	0	0	0	0	0	0
Details through which water passes	0	0	0	0	0	0
Sensor unit	0	0	0	0	0	0
Accessories	0	0	0	0	0	0

O: toxic and harmful substances in all components of device contained in an amount below limit value according to SJ / T11363-2006 «requirements limiting the presence of toxic and hazardous substances in products.»

X: indicates the presence of toxic and hazardous substances at least one of the components in this product in excess of the limit value, according to SJ / T11363-2006 «requirements limiting the presence of toxic and hazardous substances in products.»

Technology of water processing

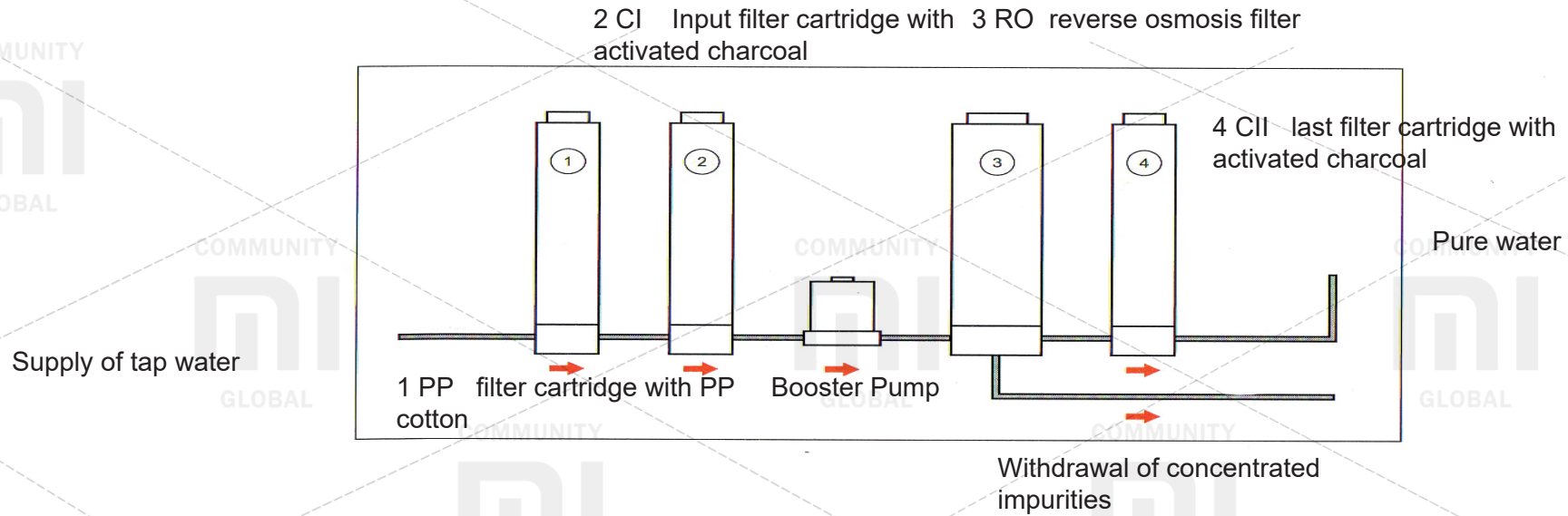

Schematic diagram

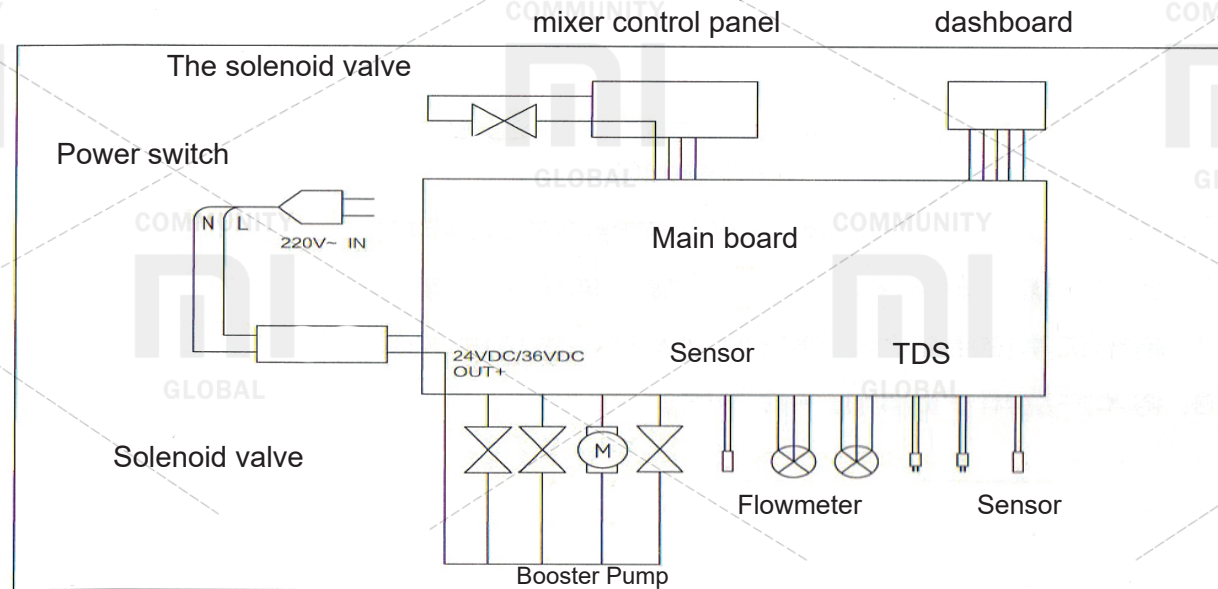

Warranty

1. Within 7 days from the date of purchase, in case of a problem of «fault list», you can choose a free replacement product, return or repair. Return of goods is only possible presentation of a valid warranty card.

2. Return of goods is only possible through the main shopping Xiaomi the official website or official website Tmall and only seven days after its purchase. You can not take the opportunity to return the product without reason within seven days after the purchase, in the event of damage to the goods incurred due to the human factor, or in the case of damage to the packaging. RIR return the goods without reason within seven days after purchase, all shipping costs borne by the consumer.

3. Within 8-15 days from the date of purchase, in case of a problem of «fault list», you choose a free replacement or repair of the goods. In the case of replacement of the goods, you can replace only the main unit and all of its components can not be replaced.

4. The warranty on the main unit and its components (except for filter cartridge) is given for 1 year, but it is necessary to properly maintain the warranty card.

The conditions are not covered by warranty

- The warranty has already expired;
- The presence of stacking faults, accessories, instructions, gifts, lack of warranty coupon;
- Damage caused by force majeure;

- Damage resulting from repairs outside the service center, improper use, falling objects, water ingress, accident, alteration, misuse, or from the use of foreign components; or if you have broken, correct serial number, security marking, etc .;

- Do not meet the model or code on the device and in the warranty card;

- Failure resulting from improper use of the device in conditions that do not correspond to the data contained in the instruction (voltage, temperature, humidity, ventilation, etc.)

- Damage resulting from exceeding the operating conditions;

- When using the device in public places.

Return and replacement devices

Classification	Term	category return and replacement of the device	Description	Start Date
Refund	7 days	Faults stipulated by the state legislation, issues of quality devices	After determining the cause of the problem consultant service center Xiaomi, you issued a document confirming the existence of quality problems of the goods	after signing the warranty card
Replacing	15 days	Faults, stipulated by the state legislation, issues of quality devices	After determining the cause of the problem consultant service center Xiaomi, you issued a document confirming the existence of quality problems of the goods	after signing the warranty card

In other words: When you return the goods without reason, within seven days after purchase, you must ensure that no damage to the main unit and its components. In the event of damage to the goods incurred due to the human factor, or in the case of damage to the package and return the goods without reason, within seven days after purchase, all shipping costs borne by the consumer.